

# ANSYS®

# 12.1

12.1 RELEASE



## ANSYS® SpaceClaim Direct Modeler™

### Product Features

#### Industry-Leading Direct Modeling

- ▶ Scale from simple shapes to complex blends and variable section sweeps
- ▶ Pull and Move tools work on both faces and edges
- ▶ Add hints for thin walls, mirrored, concentric, rounded and chamfered geometry

#### Powerful, Straightforward 3-D

- ▶ Access Pull, Move, Fill and Combine tools that enable hands-on 3-D design
- ▶ Quickly create and iterate design concepts
- ▶ Create solid models without the complexity of traditional, feature-based CAD

#### 3-D Cross-Section Creation and Manipulation

- ▶ Draw 3-D extruded, revolved and swept geometry without leaving a 2-D cross section
- ▶ Efficiently sketch out new concepts for 3-D designs
- ▶ Import complex assembly, section through it, and edit using Pull and Move tools

#### Parameters without Constraints

- ▶ To change dimension values, select what to move and edit the value
- ▶ No need to set up complicated systems of constraints
- ▶ Set up, save and share sets of dimensions

#### Flexible Assembly Structure

- ▶ Turn a part into an assembly or vice versa
- ▶ Create an assembly structure before the shape is drawn
- ▶ Draw many parts and create the structure later
- ▶ Inter-component relationships do not prevent changes
- ▶ Export subassemblies into external files for reuse in other simulations
- ▶ Incorporate existing designs for customization

### 3-D for Innovative Simulation

In today's business world, company resources are being stretched increasingly thinner; there are fewer people available to handle larger workloads, schedules are tighter and budgets are smaller. The need to cost-effectively shorten product design cycles and remove impediments to the product development process is stronger than ever.

ANSYS® SpaceClaim Direct Modeler™ software brings 3-D solid modeling to the desktops of analysts who work in a 3-D world but do not want to become experts in traditional, feature-based CAD systems. It enables product development and design engineers who are not CAD proficient to create and modify 3-D geometry models. As a result, simulation can be conducted earlier in the product development process, where it can have the most impact on performance and cost.

ANSYS SpaceClaim Direct Modeler software helps analysts interact with CAD geometry in exciting new ways. Users can easily make dramatic changes to existing models or conceptualize on the fly, and experiment with many design variations — all in a fraction of the time it would take using traditional methods.

Direct modeling revolutionizes the way engineers think about working with 3-D solid models, enabling them to focus on designing rather than working around the constraints of their parametric CAD tool. Unlike traditional, feature-based CAD, ANSYS SpaceClaim Direct Modeler software allows users to reuse data and easily incorporate geometry from other designs, even those created in CAD systems. A design can be changed however the analyst sees fit, regardless of how it was built or the CAD system in which it was created.



Intuitive tools such as Pull and Move let users directly select portions of the model and move them wherever they want. The Combine tool slices and divides parts into pieces so that portions from other designs can be merged in. The Fill tool cleans up small features and fills holes. Together, these direct-modeling tools empower users to complete jobs without resorting to traditional CAD.

**ANSYS SpaceClaim Direct Modeler  
software interoperates with all major native  
CAD and neutral file formats.**

## Product Features

### Design in Any Context

- ▶ Use the same tools to edit assemblies, parts and drawing views
- ▶ Create and make changes at any time with 3-D markups
- ▶ No need to worry about switching to the right mode

### Generate Mid-Surface Geometry

- ▶ Turn 3-D solid models into mid-surface models for shell meshing and analysis
- ▶ Extend and resolve complex 3-D intersections with direct modeling tools

### System Requirements

Operating Systems: Microsoft® Windows® XP with Service Pack 2; Microsoft Windows Vista

Video Card: requires full DirectX 9c, February 2007 edition or greater; hardware support for 64MB of graphics memory or higher; Shader 2.0 hardware support at 32 bits per pixel, 1024x768 minimum resolution; latest graphics driver

CPU: Pentium® 4 2.0GHz or Athlon™ 2000+ or faster, 32-bit (x86) or 64-bit (x64) processor

RAM: minimum 512MB RAM (32-bit); 1Gb RAM (64-bit)

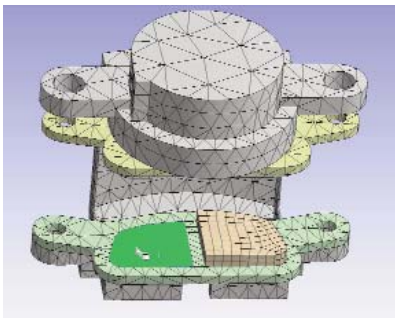

The transfer of shared topology from ANSYS SpaceClaim Direct Modeler software to the ANSYS Workbench platform is shown in this brake caliper assembly



ANSYS SpaceClaim Direct Modeler software automatically finds and fixes problematic areas, creating clean geometry for meshing and analysis.

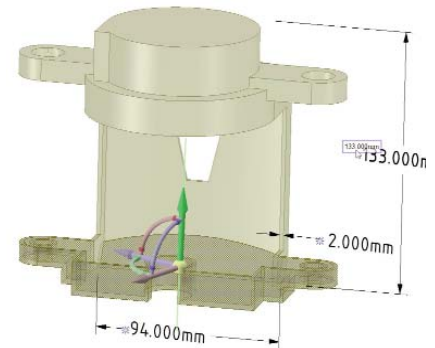

Building dimensional intelligence into dumb models for parametric studies within the ANSYS Workbench environment

### Fastest, Most Innovative 3-D Direct Modeler

ANSYS SpaceClaim Direct Modeler software enables engineers to easily create concepts and prepare existing designs for analysis and simulation. The product fully interoperates with ANSYS® 12.0 and 11.0 software as well as the ANSYS® Workbench™ platform, allowing users to:

- Rapidly create new concepts as simply as sketching them on paper; start with a blank screen and produce a concept model ready for simulation
- Import an existing CAD model designed for manufacture and prepare it for simulation; remove small surfaces, fillets and unnecessary details
- Load a non-parametric model, such as IGES, Parasolid®, etc., and manipulate it as if it were fully parametric
- Virtually test operational performance within the ANSYS Workbench simulation environment

### The ANSYS Advantage

With the unequalled depth and unparalleled breadth of engineering simulation solutions from ANSYS, companies are transforming their leading edge design concepts into innovative products and processes that work. Today, 97 of the top 100 industrial companies on the "FORTUNE Global 500" invest in engineering simulation as a key strategy to win in a globally competitive environment. They choose ANSYS as their simulation partner, deploying the world's most comprehensive multiphysics solutions to solve their complex engineering challenges. The engineered scalability of our solutions delivers the flexibility customers need within an architecture that is adaptable to the processes and design systems of their choice. No wonder the world's most successful companies turn to ANSYS — with a track record of almost 40 years as the industry leader — for the best in engineering simulation.